

MICHELLE LEI

LM

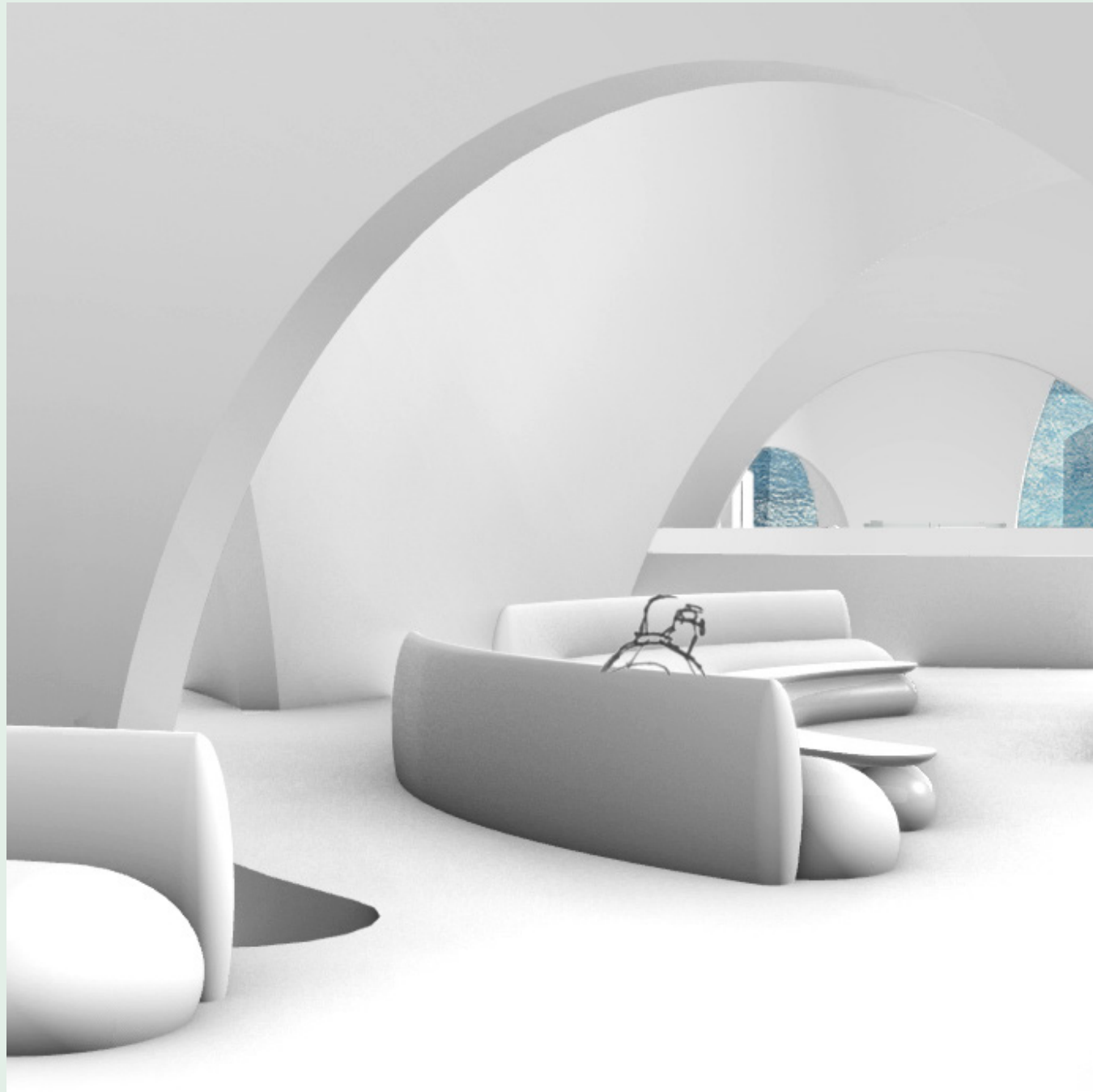

EXTREME OVERREACTION

A focus on humans tendency to overreact to threats and their inclination to overcorrect situations in extreme situations with extreme solutions - in this scenario, the consequences of climate change has led humans to take extreme measures for self-preservation.

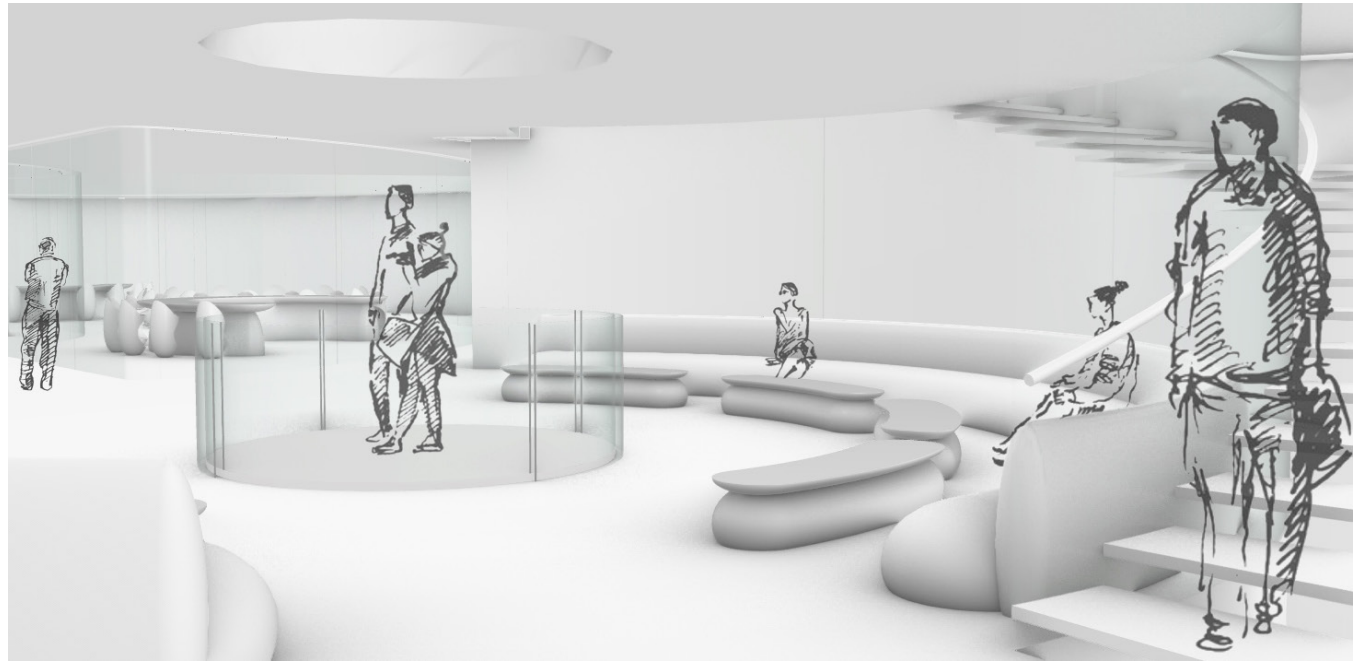

Quia derferessi aut et andit
voluptat omnissequam, te no

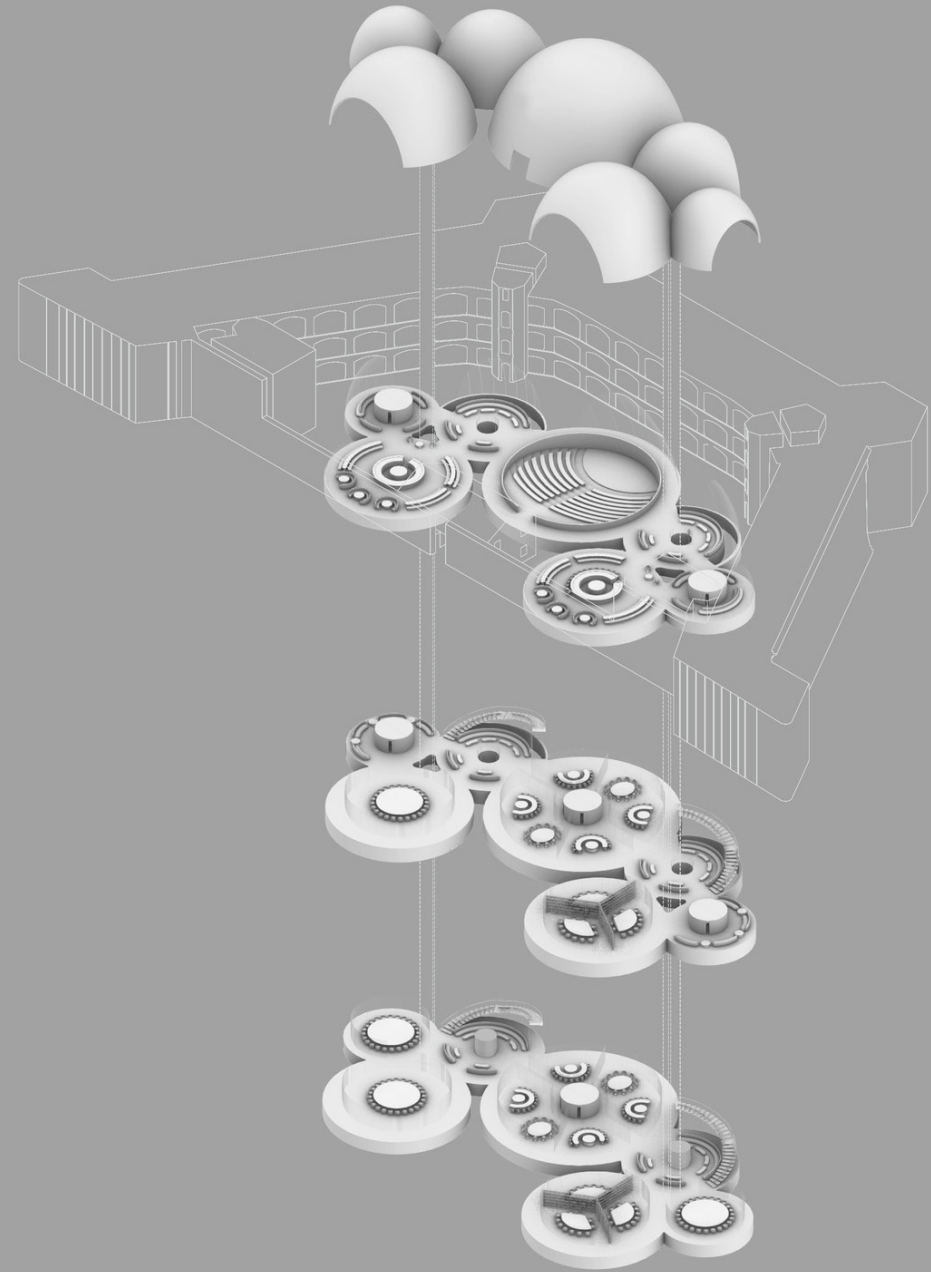

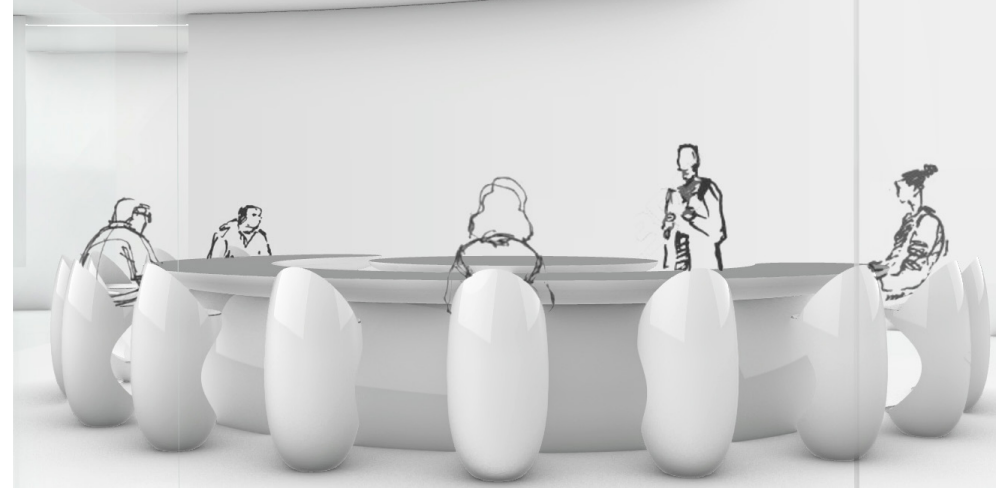
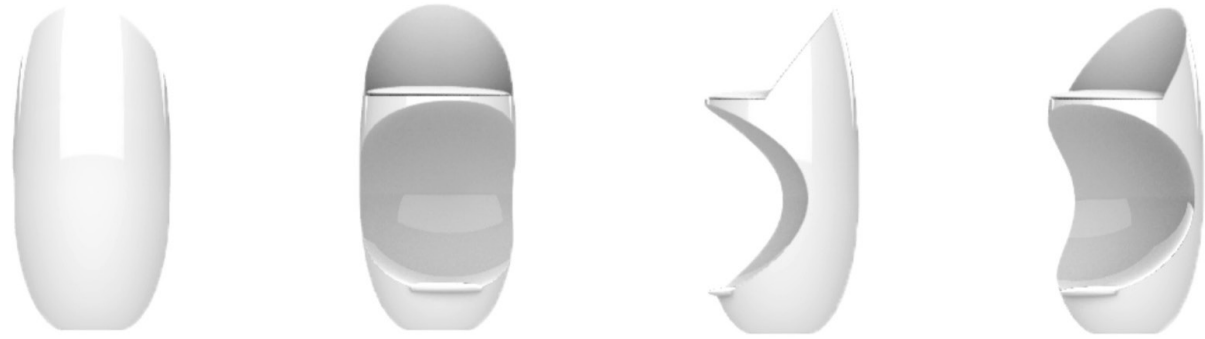

Perspective views of chairs used by different disciplines.

Am et eum fuga. Pa eatur rem quia
sinus si quidentius evero core

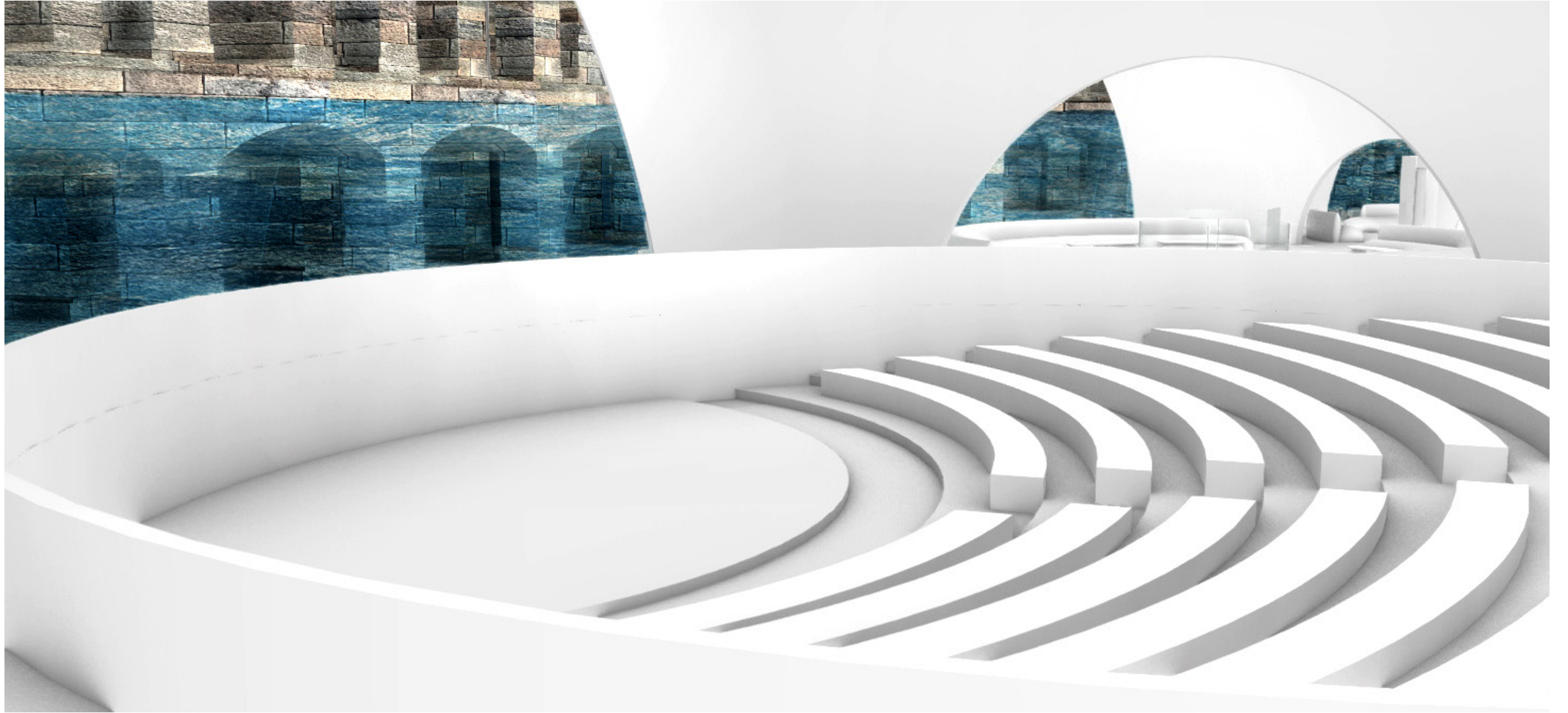

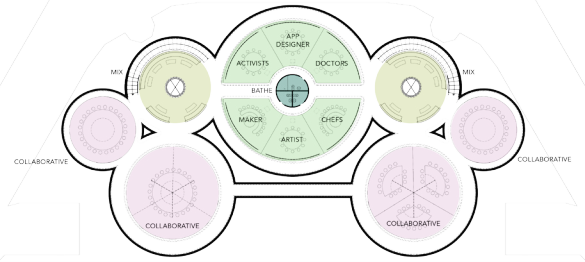
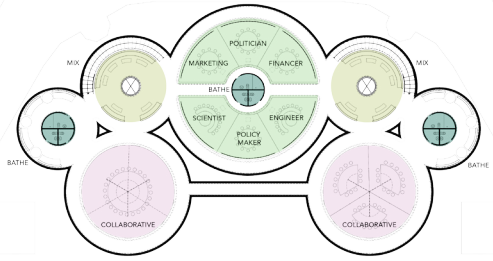
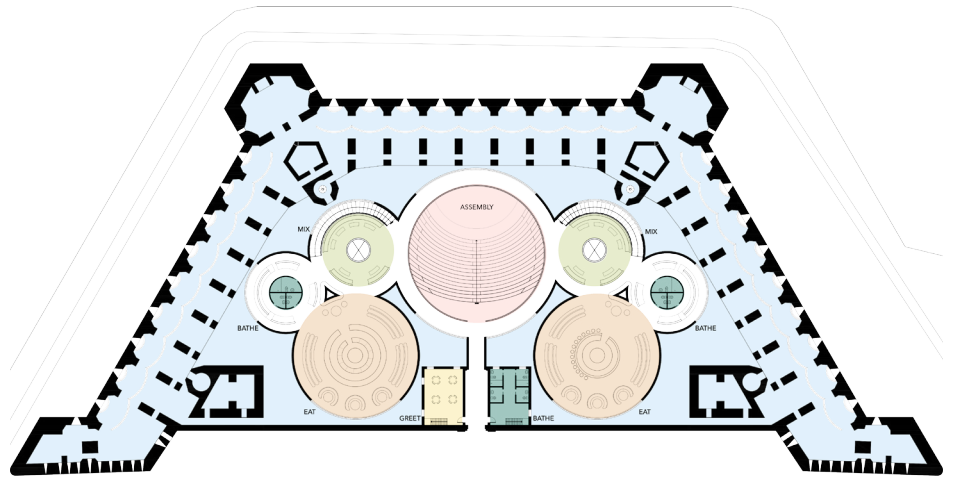

Am et eum fuga. Pa eatur rem quia
sinus si quidentius evero core





EAST HALL

Documentation of Pratt Institute's East Hall vestibule.

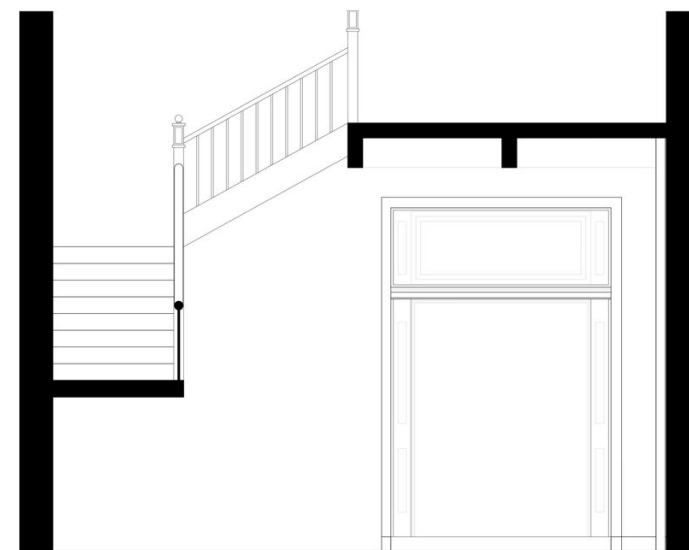
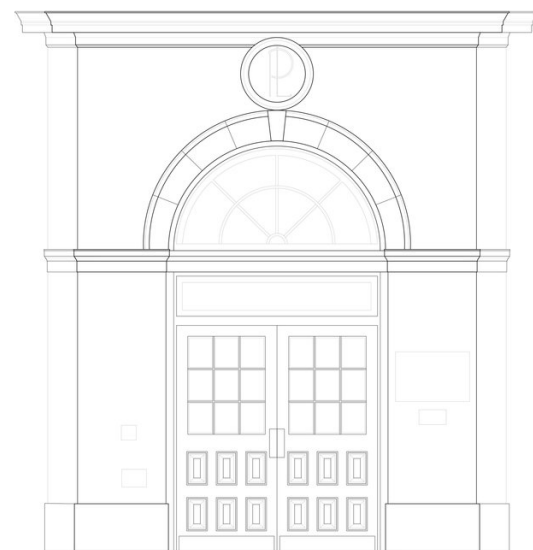
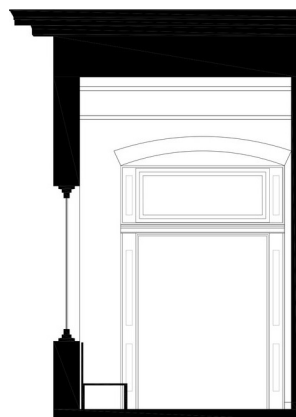
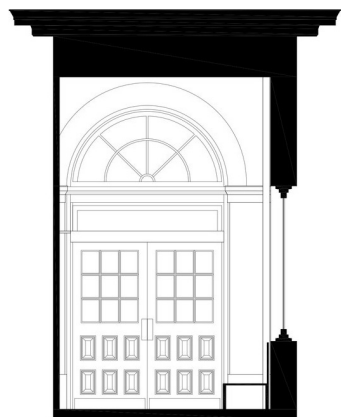
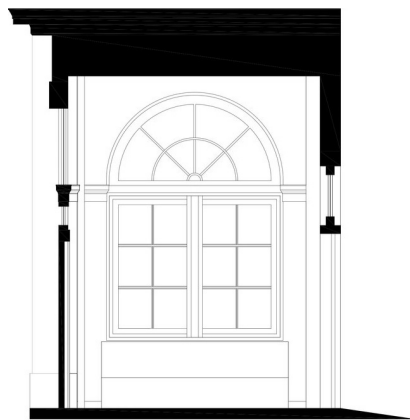
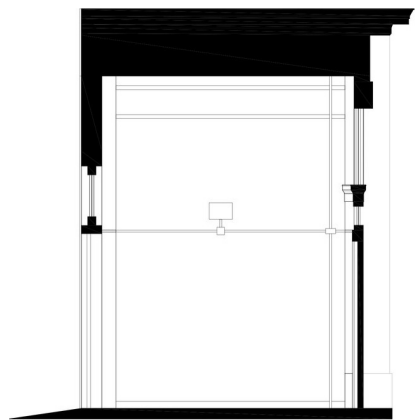

Exterior and interior elevations drawn as DWGs in AutoCad.

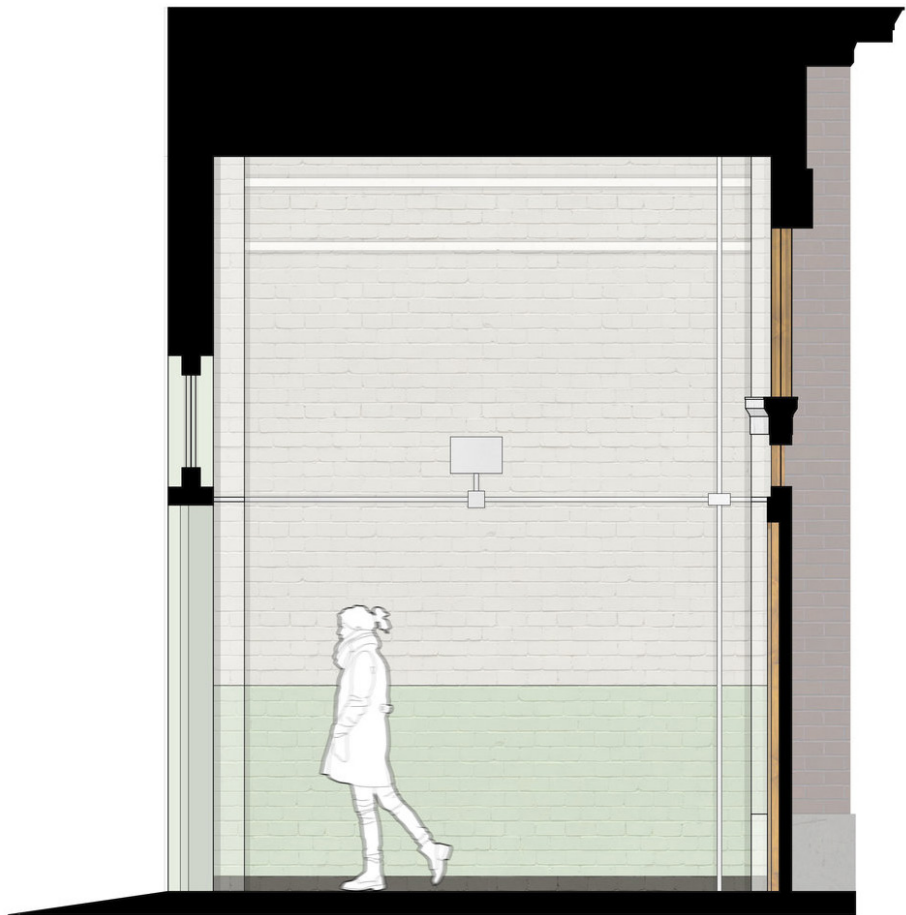

Collage used to recreate environment with color and texture in Photoshop.

Exploded Axonometric projection created using SketchUp and Photoshop to recreate the original space with a proposed bench.

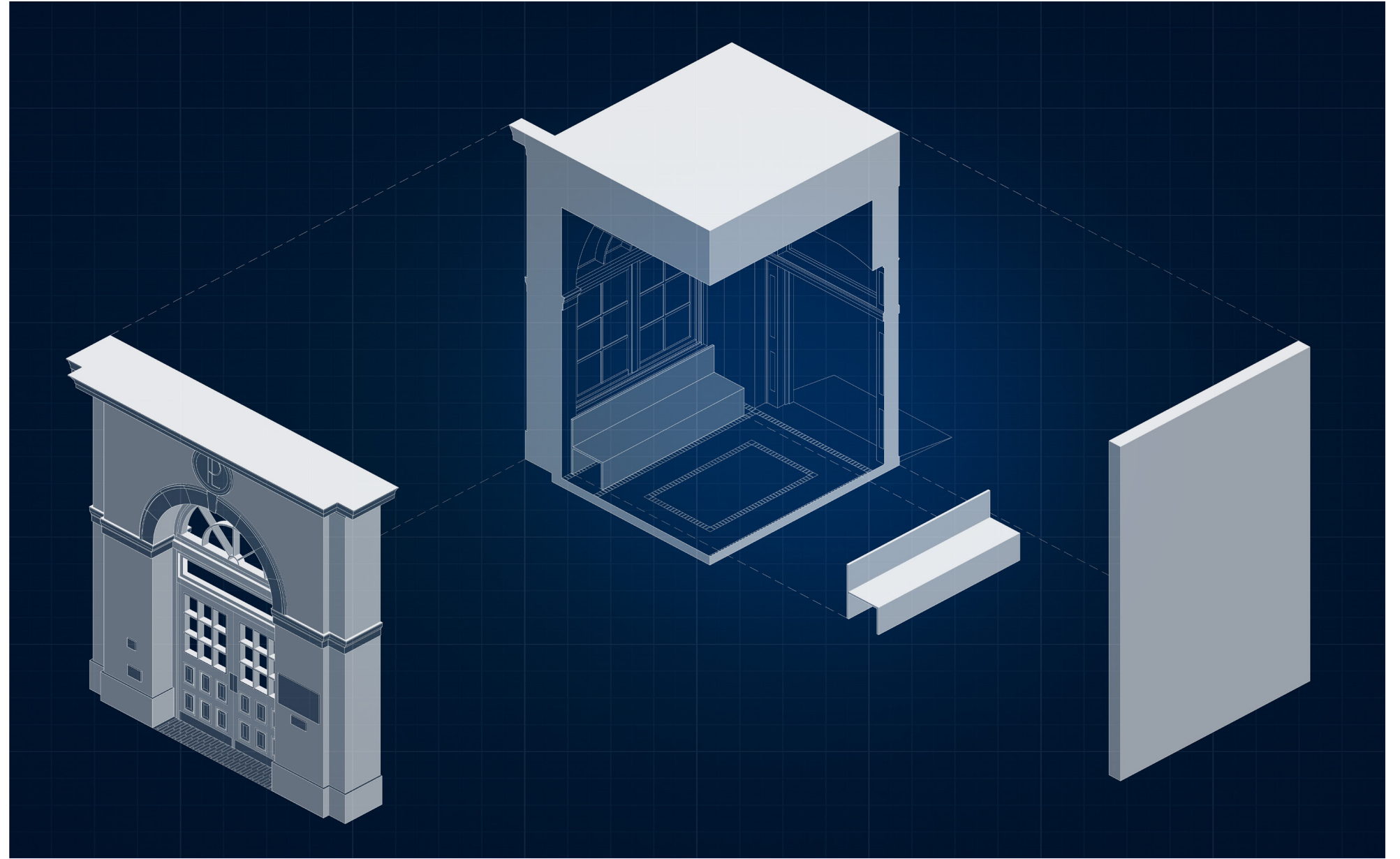



(626) 616 - 2345

MICHELLESJLEI@GMAIL.COM

WWW.MICHELLELEI.ME